











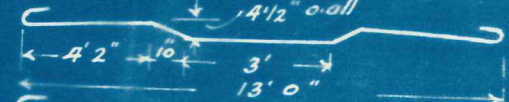



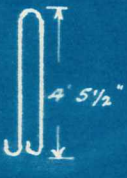
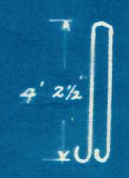
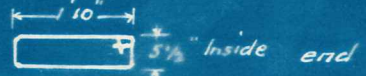

Location	Description	Mark	φ	Cut length	No in Each	Total
Deck		D41	1/2	13'-10"	34	136
		D42	1/2	11'-10"	34	136
		D43	1/2	14'-0 1/2"	33	132
		D44	1/2	12'-6"	21	84
		D45	1/2	19'-0"	42	168
Kerb		K41	1/2	12'-6"	4	16
		K42	1/2	19'-0"	8	32
Deck Handrails		K31	3/8	5'-9"	60	240
		D46	1/2	8'-8"	6	48
		H31	3/8	13'-3"	4	32
Posts		H8φ1	8φ	2'-0"	7	336
		H41	1/2	10'-0"	4	40
		H42	1/2	4'-11"	4	16
		H8φ2	8φ	5'-6"	4	16
		H8φ3	8φ	2'-6"	4	160
		H8φ4	8φ	3'-6"	8	48
Panels		H33	3/8	2'-9"	10	480
		H34	3/8	6'-4 1/2"	2	48
		H35	3/8	6'-7"	2	48
Beams		B1	1 1/4	29'-3"	2	16
		B2	1 1/4	36'-9"	2	16
Piers		PI01	1 1/4	11'-0"	3	18

Reinforcement Bending Schedule

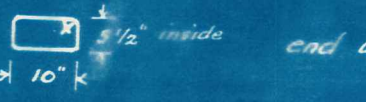
MANUHERIKIA DOWNS RD BRIDGE

R.J. Black  
County Engr.  
Sept. 40

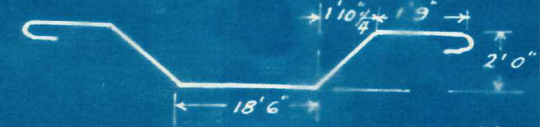
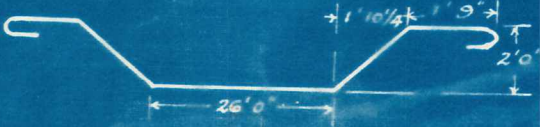
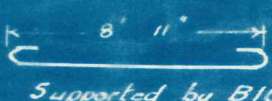
CONT. No 311

M.C.C. 148d. 1/16

Sheet 4

Location	Description	Mark	φ	Cut length before bending	No in Each	Total
Beam		B103	1 1/4	48' - 3"	2	16
		B104	1 1/4	48' - 3"	2	16
		B105	1 1/4	47' 0"	4	32
		B41	1/2	6' - 11 1/2"	60	480
		B106	1 1/4	1' 0"	16	128
		T31	3/8	5' - 6"	9	36
		<del>A51</del>	<del>5/8</del>	<del>16' 9"</del>	<del>6</del>	<del>12</del>
		<del>A71</del>	<del>7/8</del>	<del>17' 3"</del>	<del>2</del>	<del>4</del>
		<del>A81</del>	<del>1"</del>	<del>17' 5"</del>	<del>2</del>	<del>4</del>
		A71	5/8	14' 0"	4	8
	A71	7/8	14' 9"	4	8	
	A81	1	14' - 11"	3	6	
Transv. Beam		T41	1/2	14' 2"	2	8
		T81	1	13' 0"	2	8
Abutmt.		A61	3/4	14' 9"	4	8
		A54	5/8	12' 0"	13	26
		A53	5/8	12' 0"	13	26
Wing wall		A54	5/8	7' 3"	29	58
		A85	N#8	3' 6"	73	146
		<del>W41</del>	<del>1/2"</del>	<del>-</del>	<del>10</del>	<del>40</del>
		<del>W52</del>	<del>5/8</del>	<del>-</del>	<del>9</del>	<del>36</del>
		<del>W51</del>	<del>5/8</del>	<del>9' 6 1/2"</del>	<del>5</del>	<del>10</del>
		<del>W43</del>	<del>1/2"</del>	<del>9' 4"</del>	<del>2</del>	<del>8</del>

Reinforcement Bending Schedule

MANUHERIKIA DOWNS RD BRIDGE, 52

CONT. No 311

R.J. Black  
County Engr.  
Sept. 40

M.C.C. 148e

Sheet 5

Location	Description	Mark	φ	Cut Length	No in Each	Total	
Wing wall base		W82	1"	12' 0"	1	4	
		W71	7/8"	11' 10"	2	8	
		W81	1"	11' 8"	1	4	
		W72	7/8"	11' 0"	2	8	
		W83	1"	11' 2"	1	4	
	Length over hooks						
		7 @ 13' 2"	W53	5/8"	14' 2 1/2"	odd	24
		1 @ 12' 2"			13' 2 1/2"		
		1 @ 10' 6"			11' 6 1/2"		
		1 @ 8' 9"			9' 9 1/2"		
	1 @ 7' 4"	8' 4 1/2"					
		W42	1/2"	10' 8"	11	44	
	1 @ 8' 10"			9' 8"			
	1 @ 7' 2"			8' 0"			
	1 @ 5' 4"			6' 2"			
	1 @ 4' 0"			4' 10"			
Piers		P81	1"	13' 9"	1	3	
		P82	1"	18' 0"	2	6	
		P71	7/8"	17' 6"	6	18	
		P51	5/8"	15' 6"	6	18	
		P52	5/8"	14' 0"	6	18	
		P53	5/8"	12' 6"	11	33	
	Stirrups		P54	5/8"	11' 0"	24	72
		P31	3/8"	7' 3"	4	12	
		P55	5/8"	9' 9"	4	12	

Deleted

Reinforcement Bending Schedule

MANUHERIKIA DOWNS RD BRIDGE

R.J. Black  
County Engr.  
Sept. 40

CONT. No 311

M.C.C. 148f

Sheet 6

153  
110

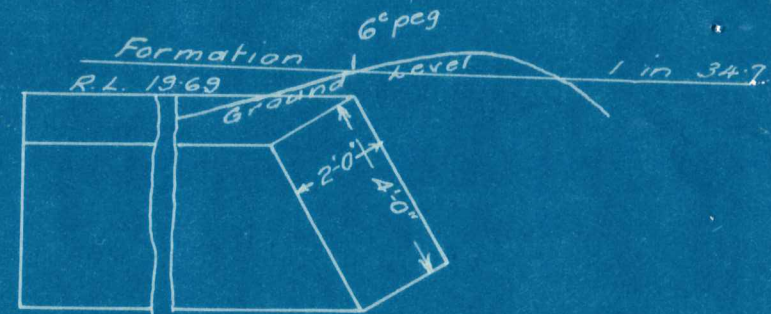
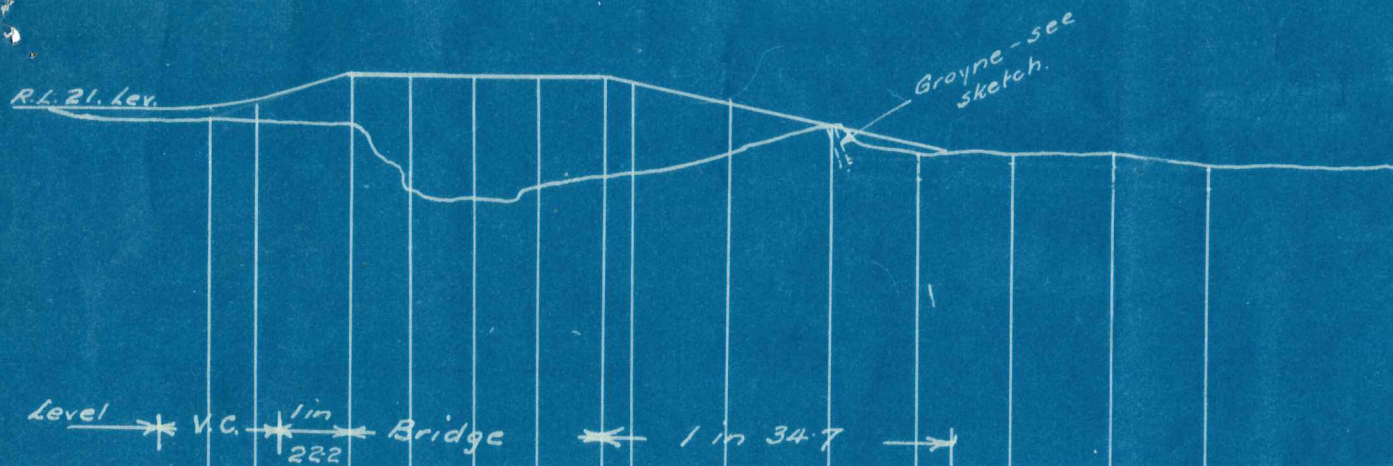

Section on Road  $\phi$

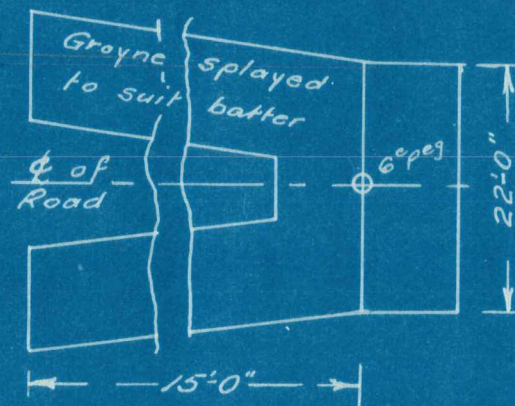

Plan

Groyne Detail.

Bank

Formation Lev.

Reduced Lev

Distances

1.30	2.36	5.05				10.02	9.40	5.04						
21.3	21.80	24.50	24.62	24.75	24.62	24.50	24.00	22.09	20.19	18.28	17.28	17.80	16.20	
20.00	19.44	19.45	18.40	12.15	13.05	14.48	14.60	17.03	20.19	16.56	17.28	17.80	16.20	
-50	0	1	1.68.18	2.36.36	3.04.54	3.72.73	4	5	6	7	8	9	10	

Scales - Horiz. 2ch to 1"  
Vert. 20' to 1"

Manuherikia Bridge.

St Bathans Downs Road.

Proposed Alterations to Approaches.

M.C.C. 147.

Copy of P.W.D. 105676

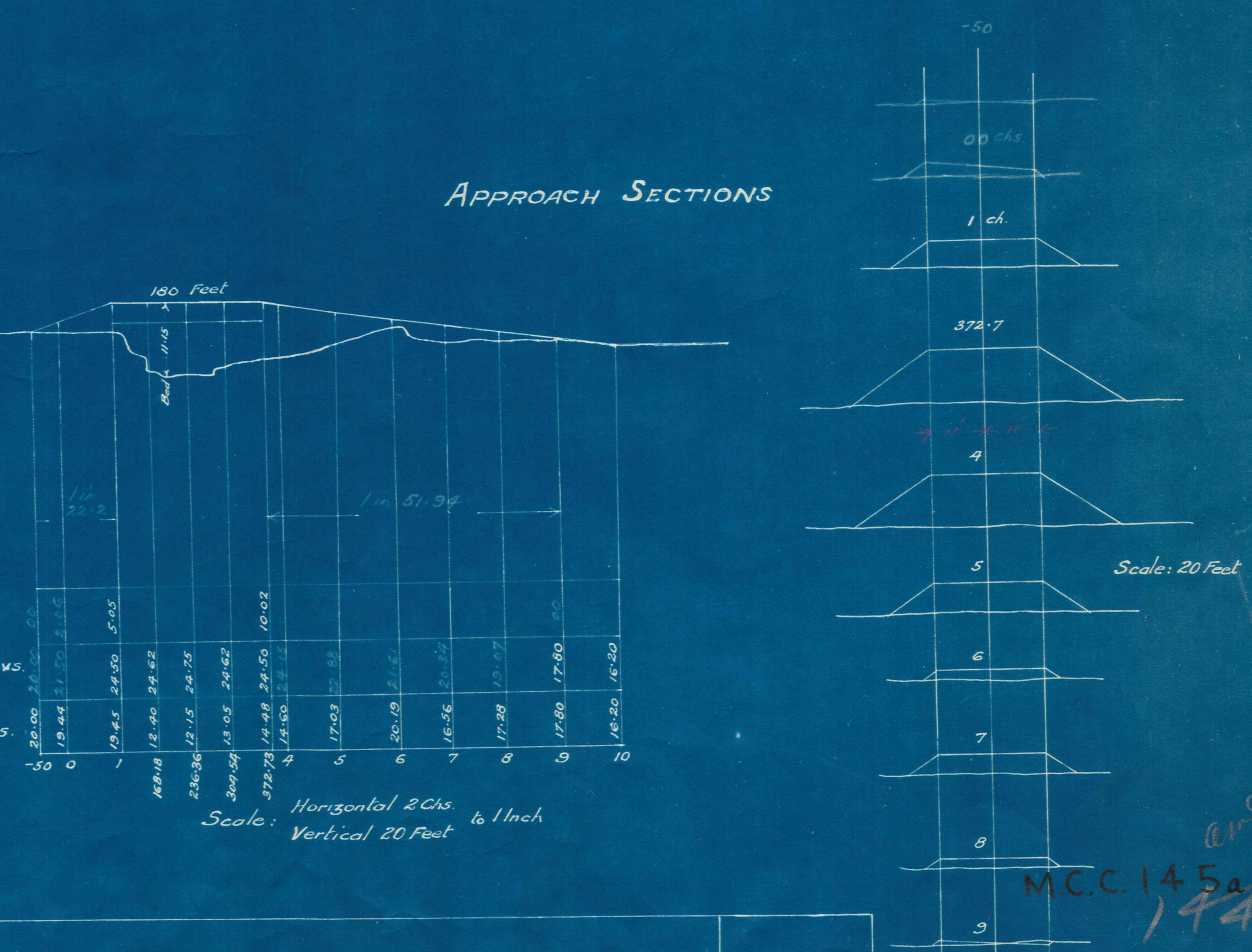
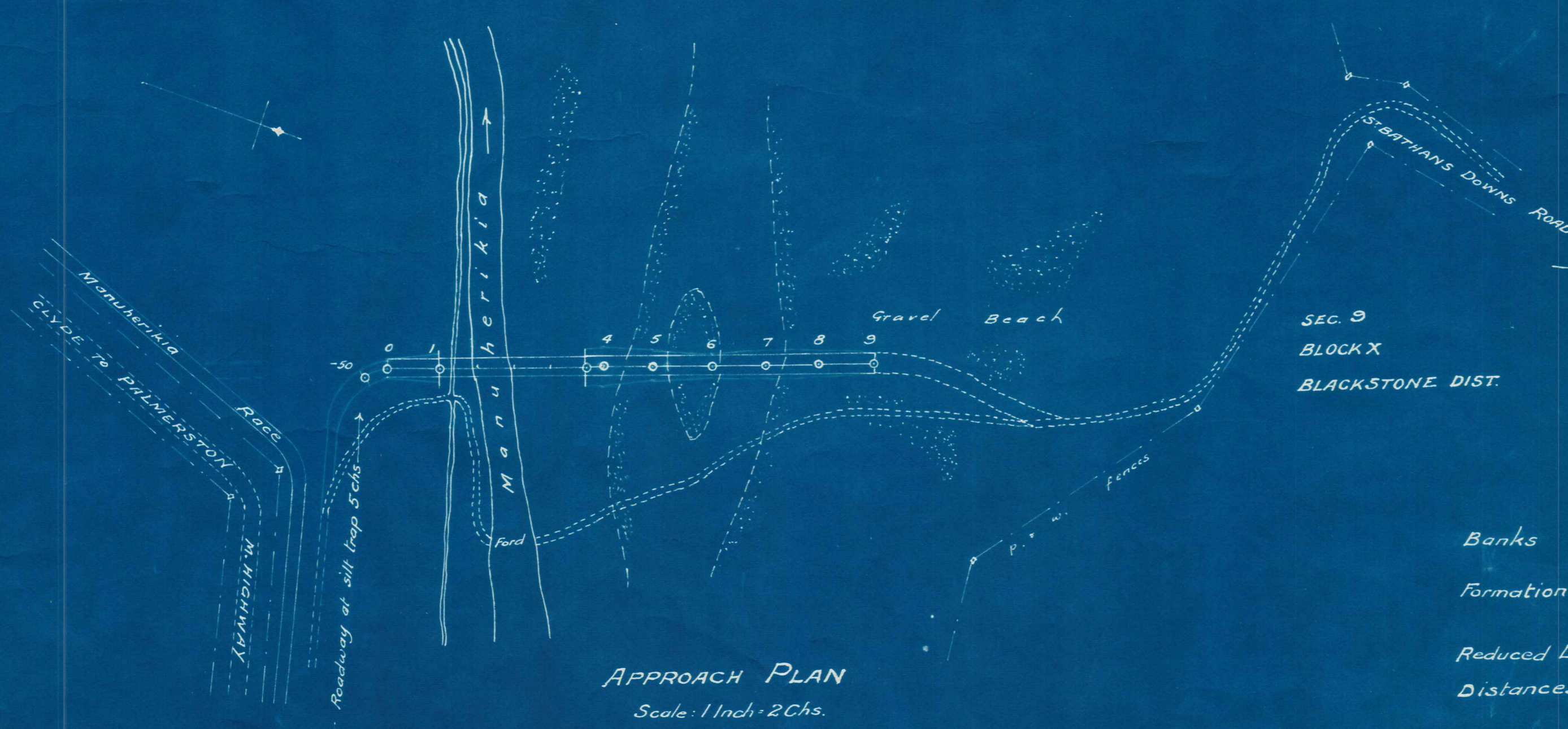
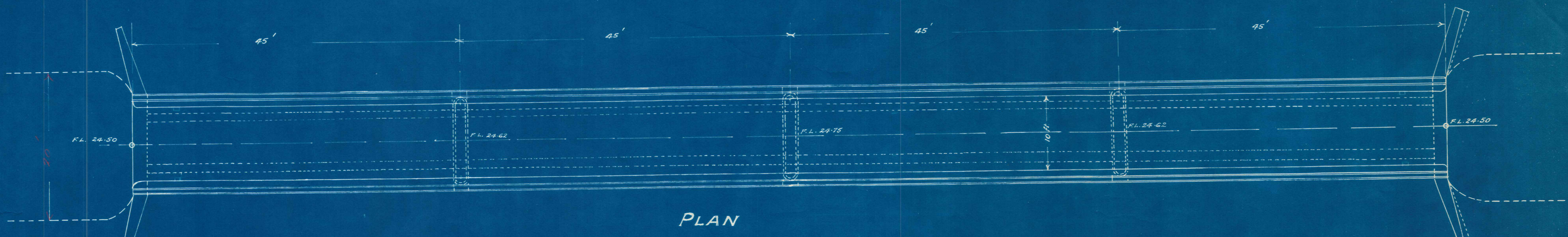
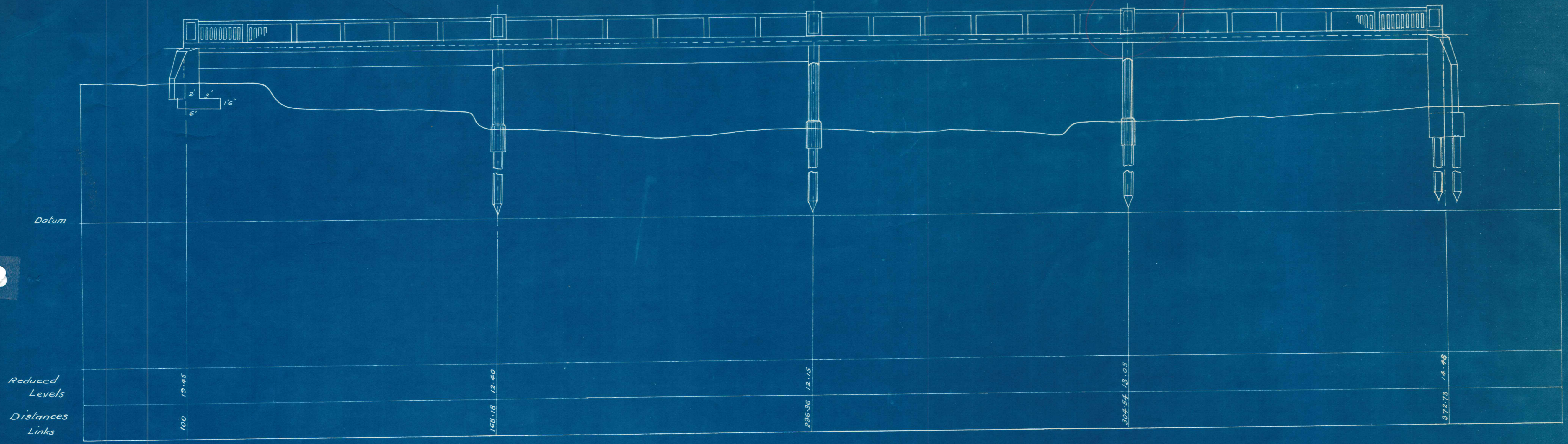

911

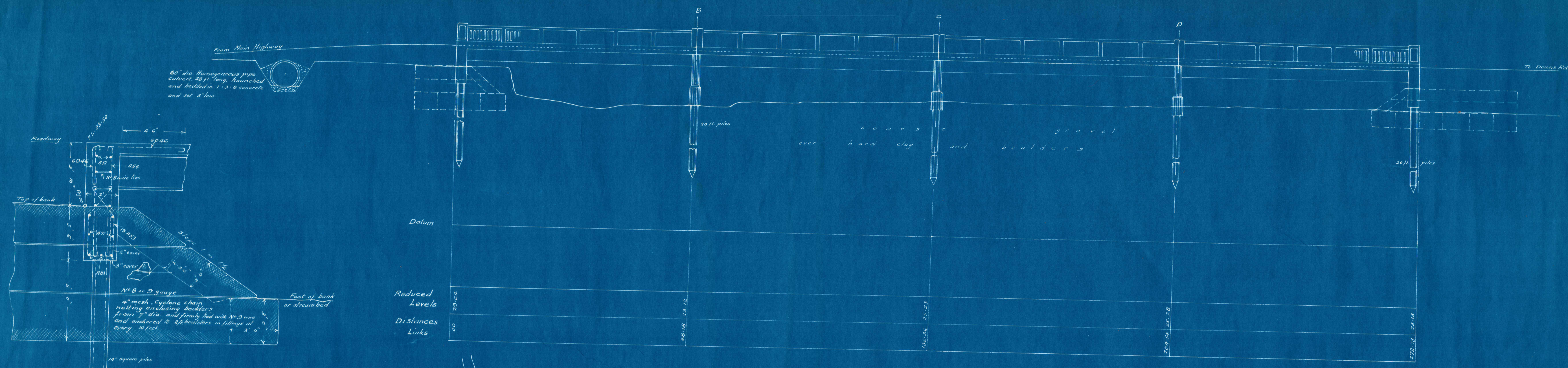

SECTION AT SOUTH ABUTMENT

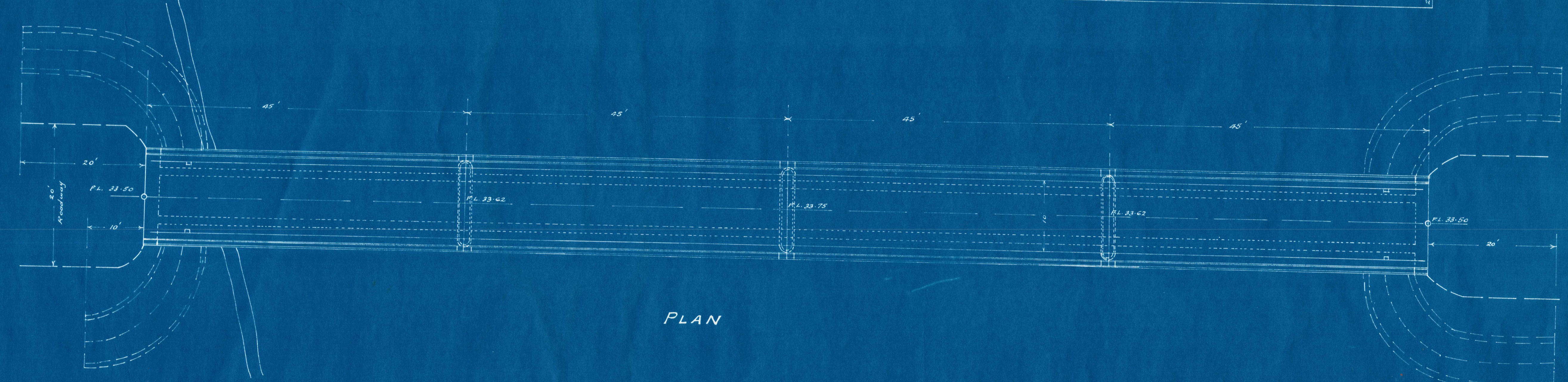

PLAN

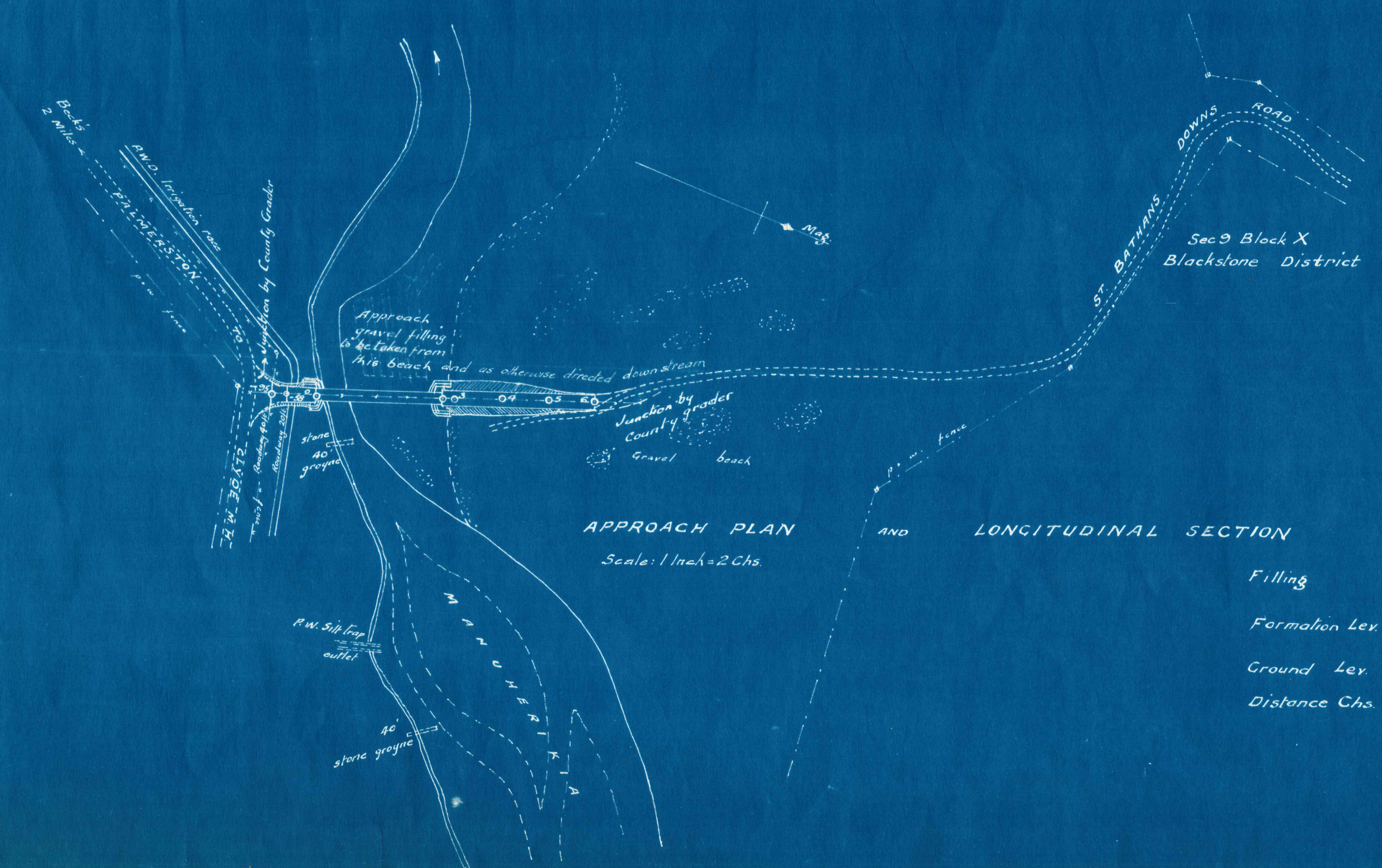

APPROACH PLAN  
Scale: 1 inch = 20 feet

LONGITUDINAL SECTION

Station	Formation Lev.	Ground Lev.	Distance Cha.
0+00	272.3	272.3	0
0+10	272.3	272.3	10
0+20	272.3	272.3	20
0+30	272.3	272.3	30
0+40	272.3	272.3	40
0+50	272.3	272.3	50
0+60	272.3	272.3	60
0+70	272.3	272.3	70
0+80	272.3	272.3	80
0+90	272.3	272.3	90
1+00	272.3	272.3	100
1+10	272.3	272.3	110
1+20	272.3	272.3	120
1+30	272.3	272.3	130
1+40	272.3	272.3	140
1+50	272.3	272.3	150
1+60	272.3	272.3	160
1+70	272.3	272.3	170
1+80	272.3	272.3	180
1+90	272.3	272.3	190
2+00	272.3	272.3	200
2+10	272.3	272.3	210
2+20	272.3	272.3	220
2+30	272.3	272.3	230
2+40	272.3	272.3	240
2+50	272.3	272.3	250
2+60	272.3	272.3	260
2+70	272.3	272.3	270
2+80	272.3	272.3	280
2+90	272.3	272.3	290
3+00	272.3	272.3	300

Scale: 2 Chs & 20 ft. to an inch

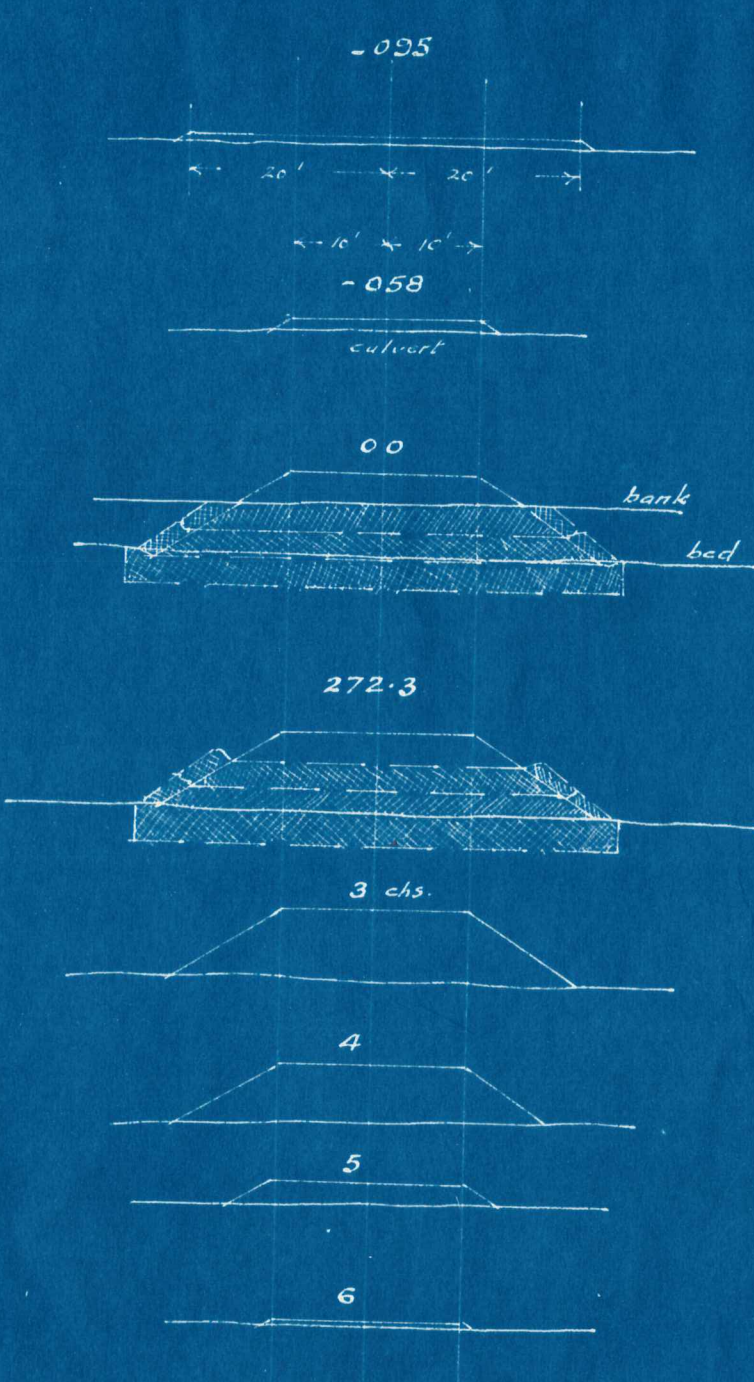

APPROACH CROSS SECTIONS  
Scale: 20 Feet

1986

M.C.C. 148a

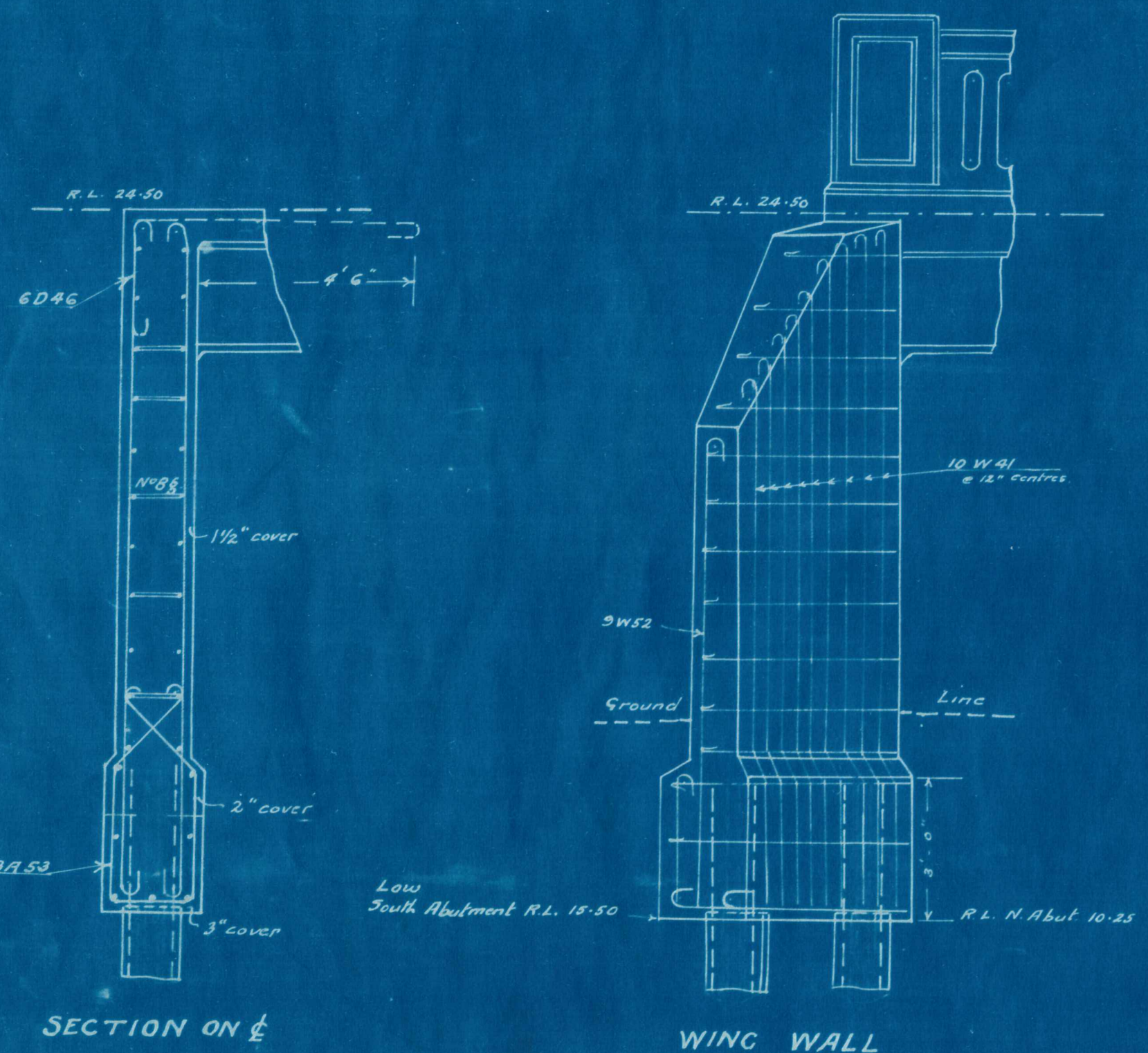
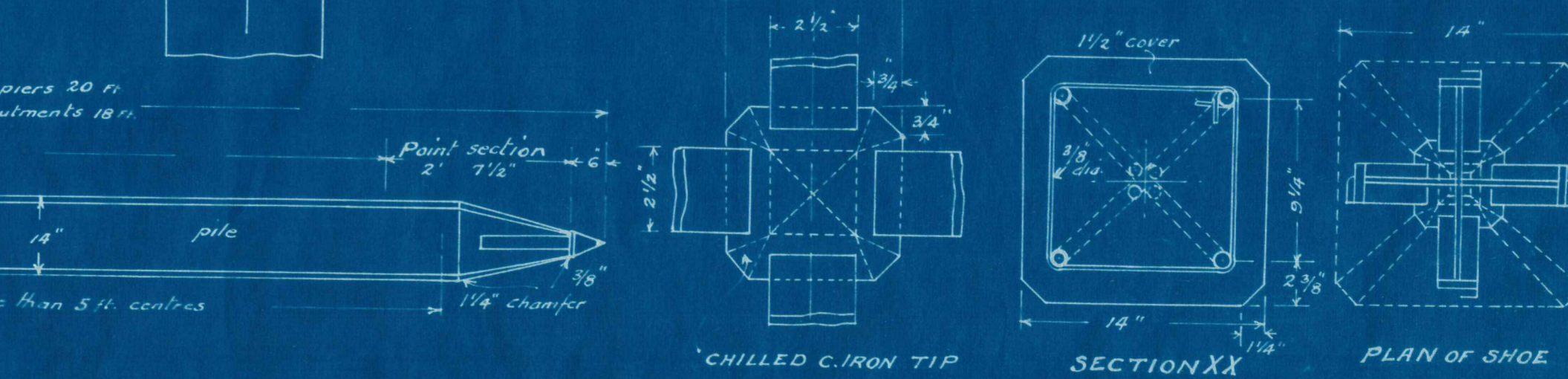
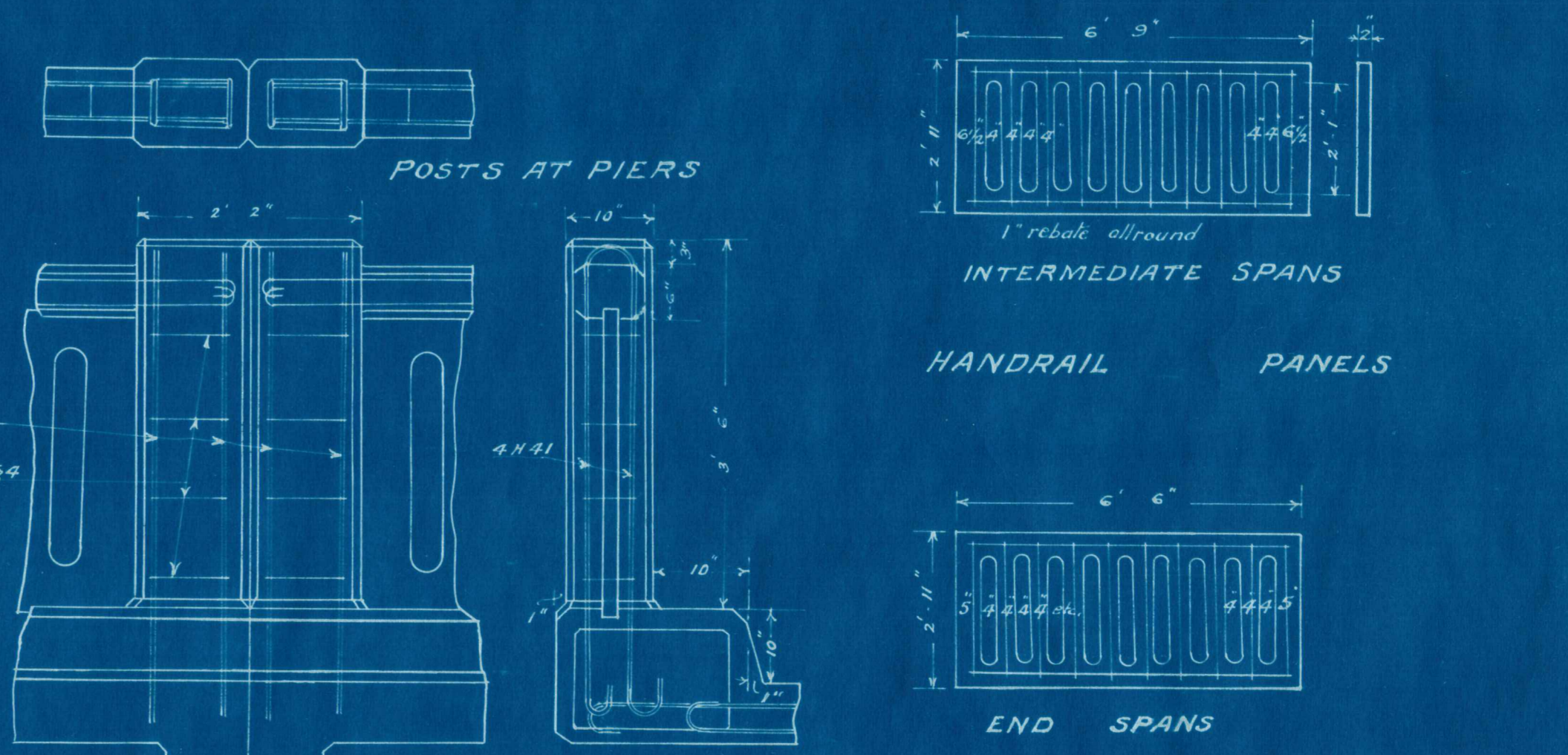
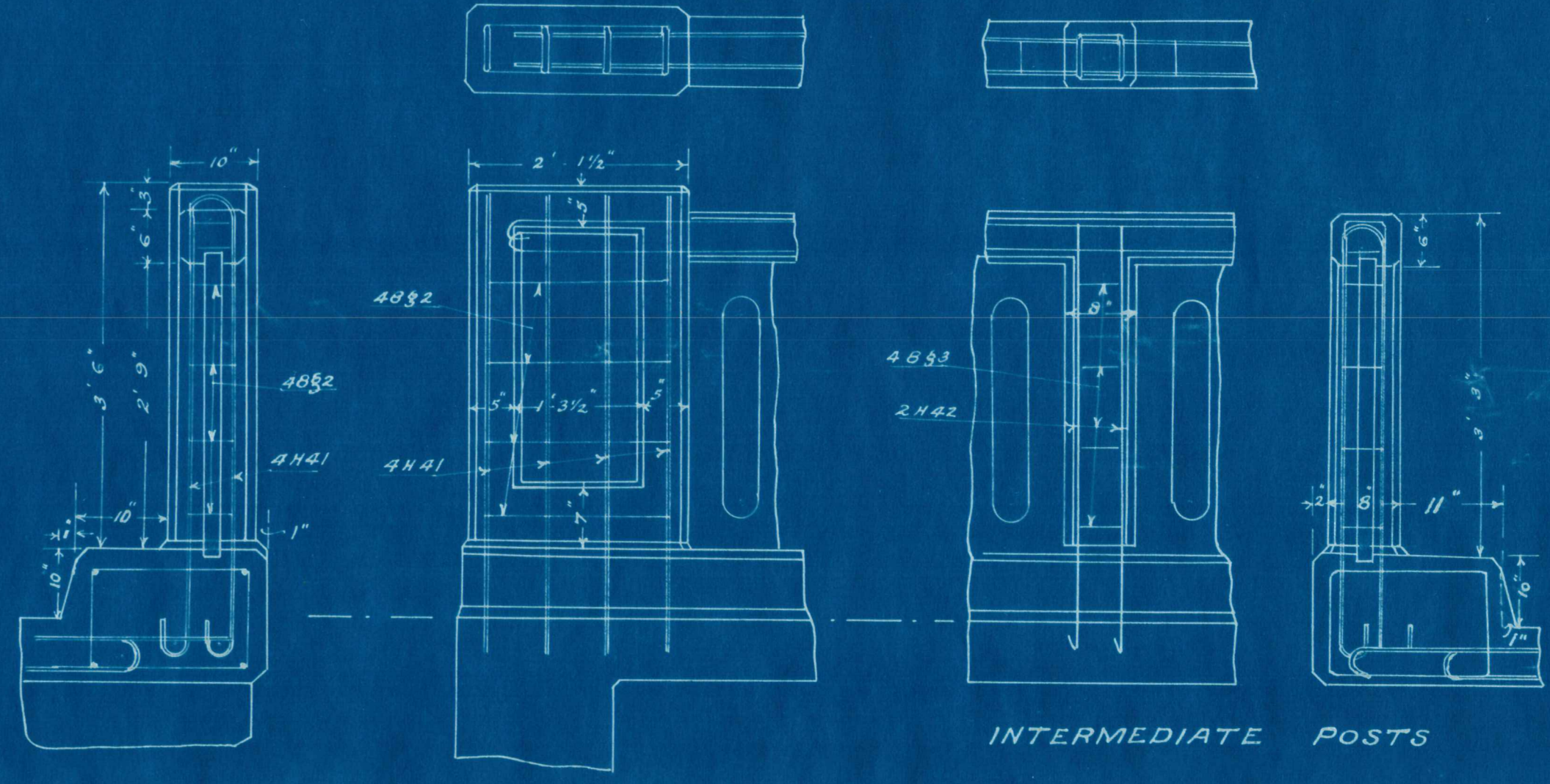
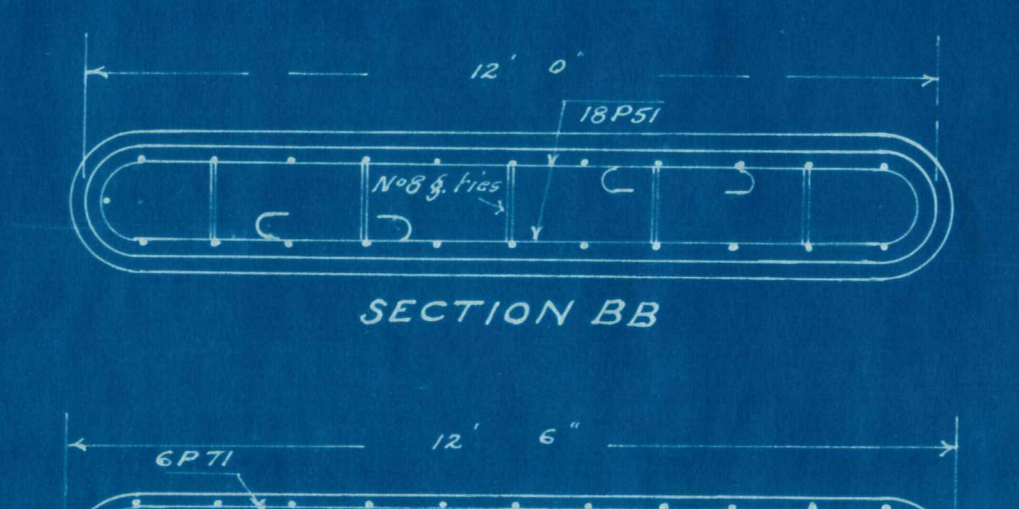
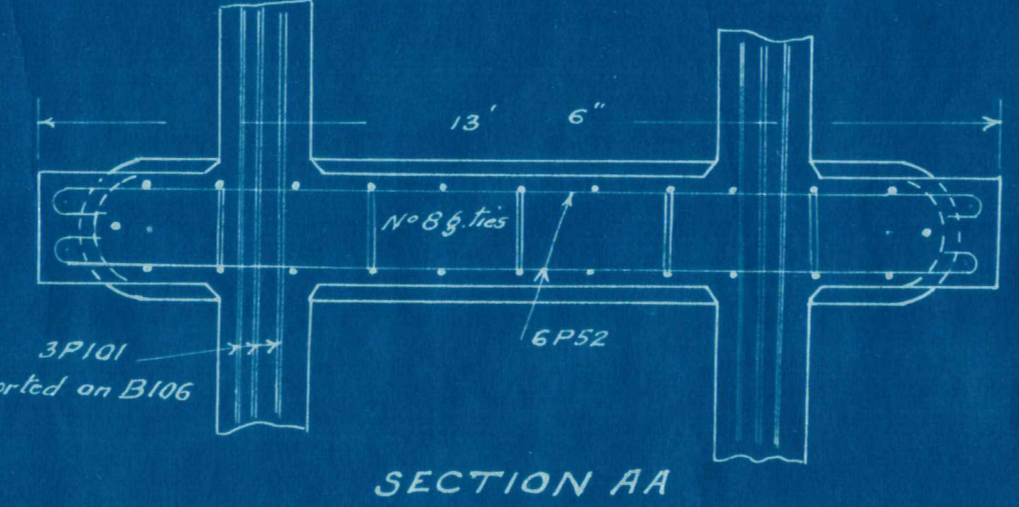
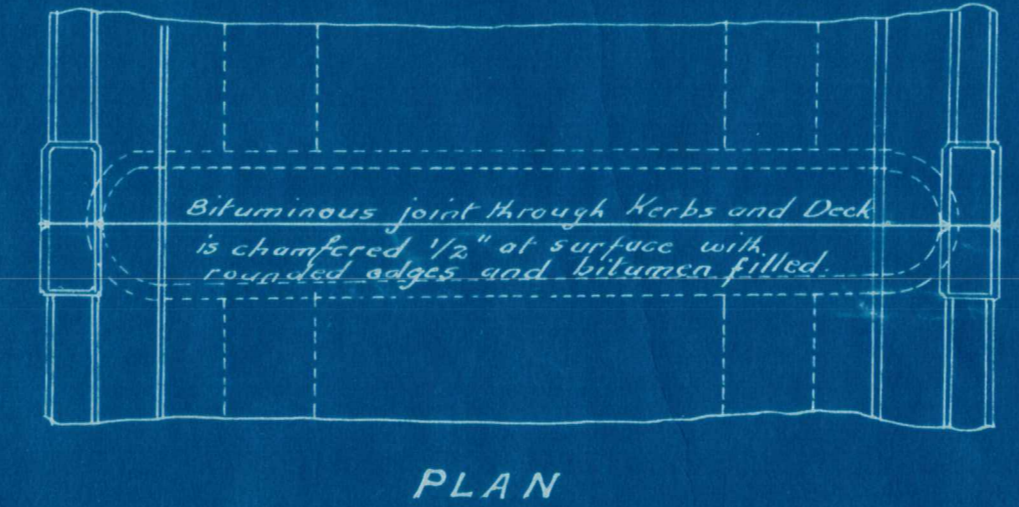
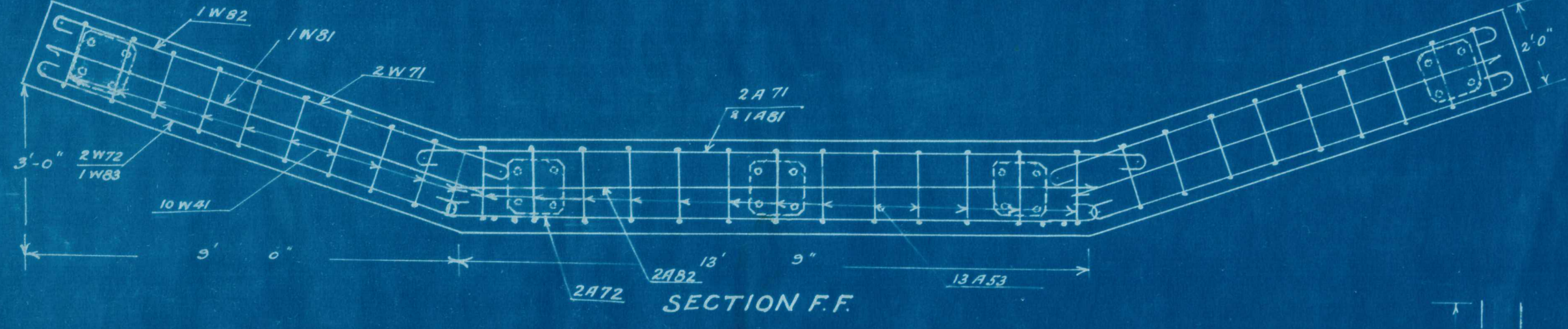
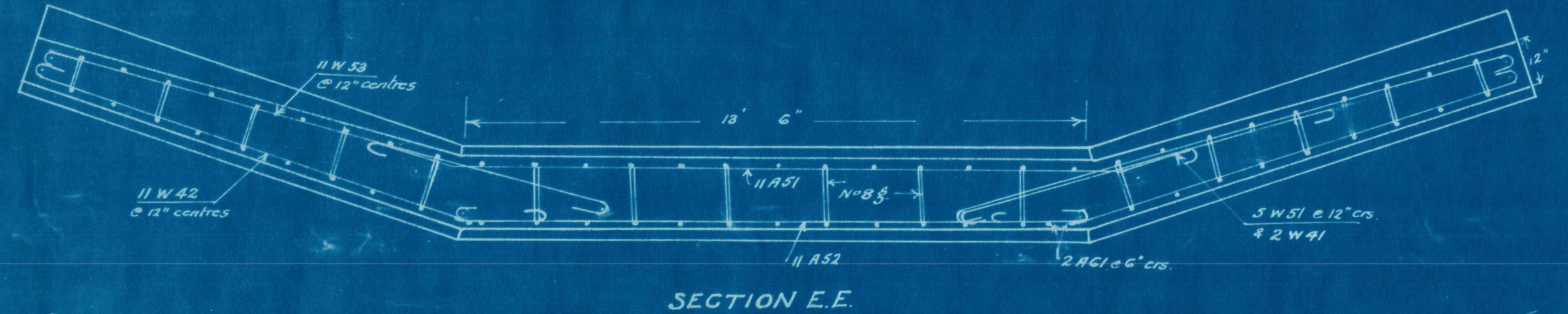
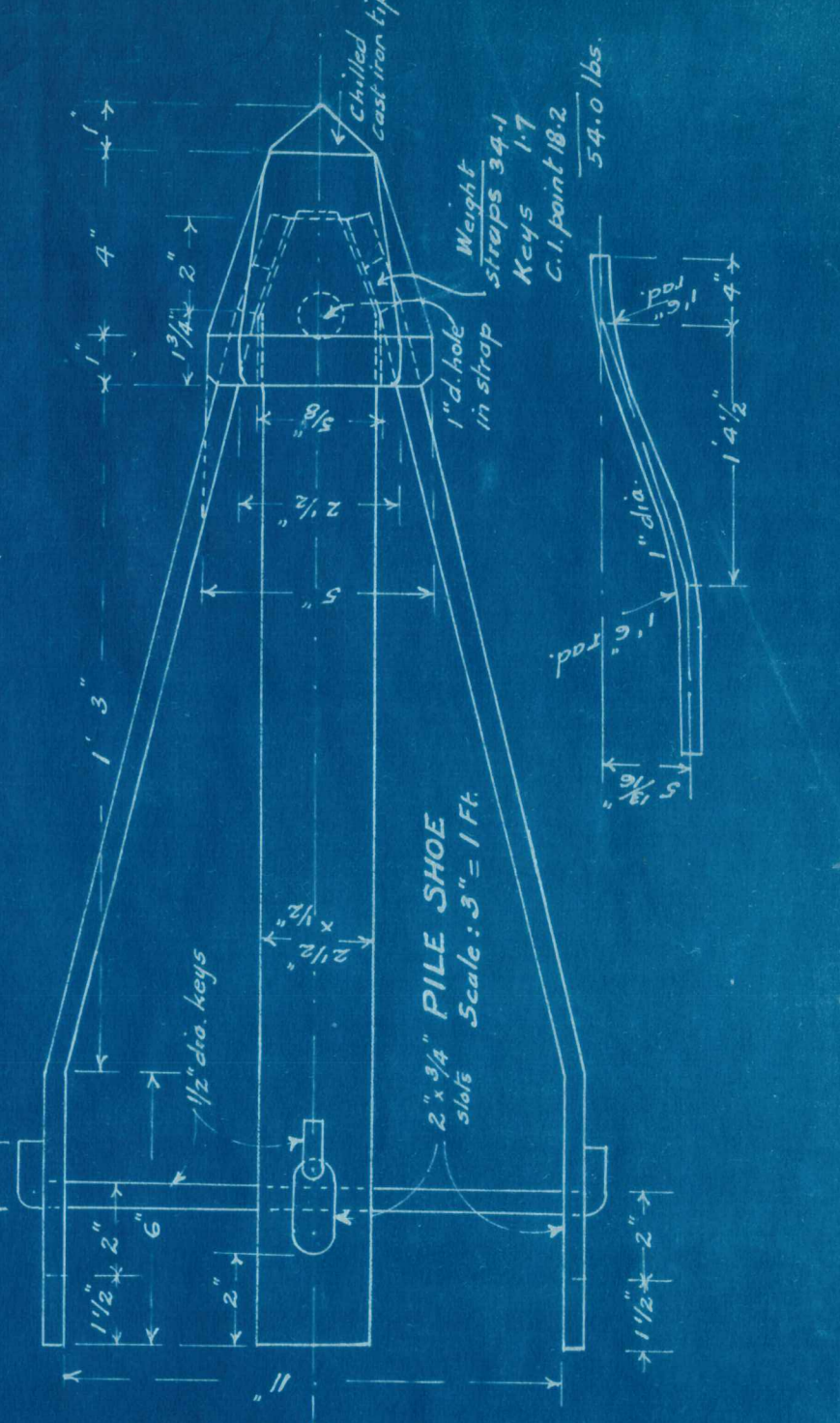
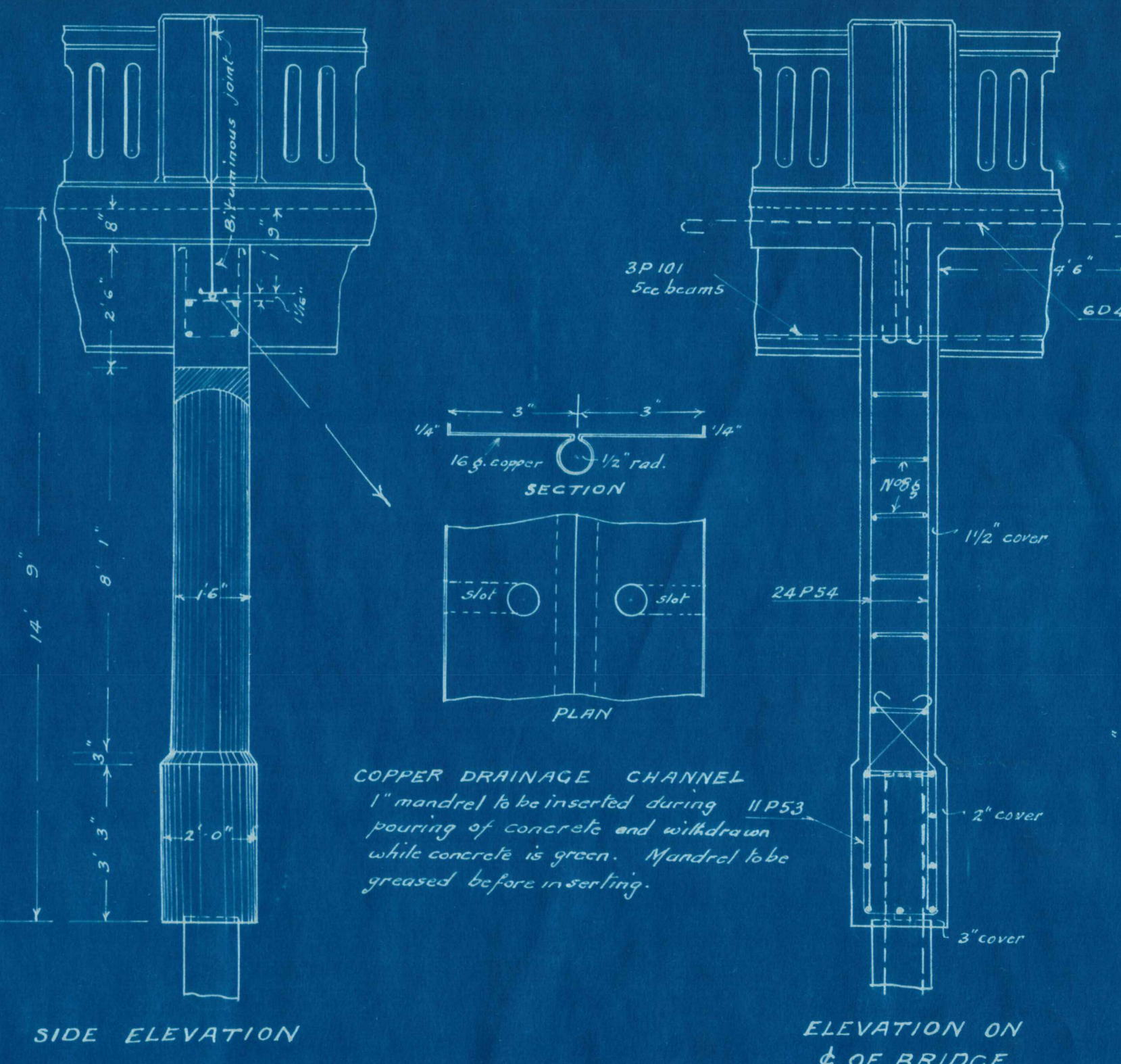
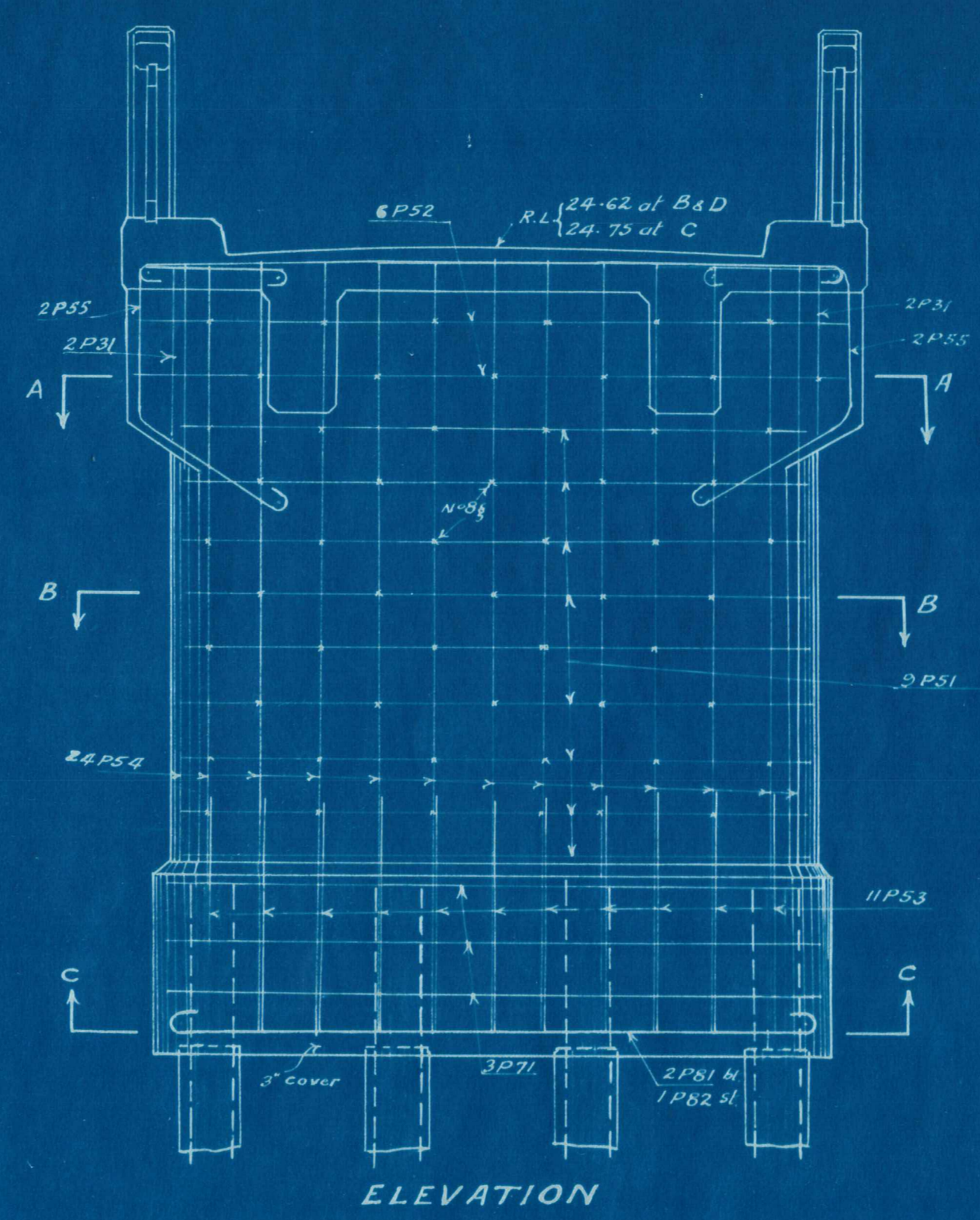
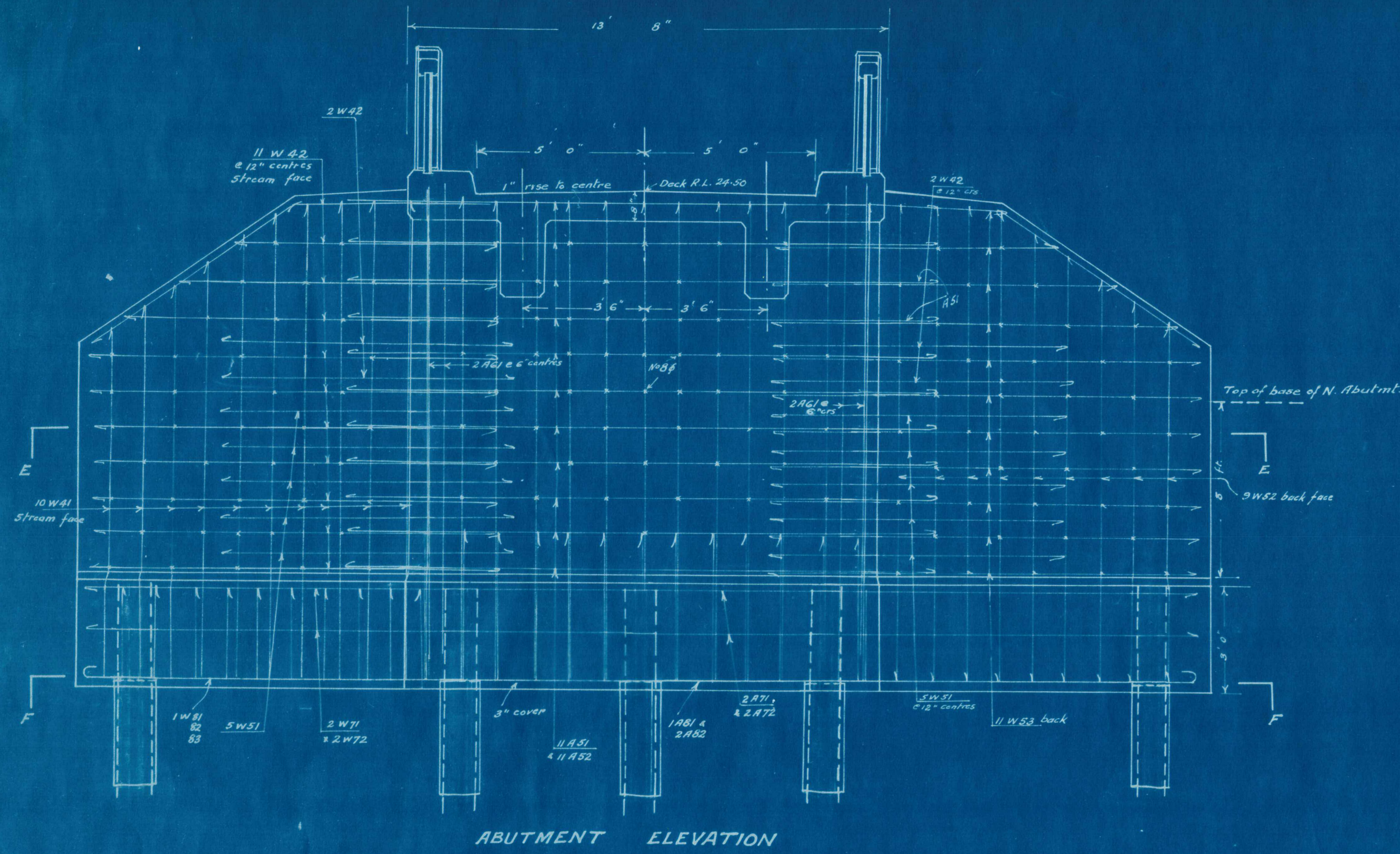

**PILE HEAD**  
Concrete in pile heads to be completely cut away for the distance shown. The helical winding may be either lightly re-wound and tied round vertical pile rods, or it may be cut off due or three turns above the solid concrete and the ends lightly bent round a pile rod.

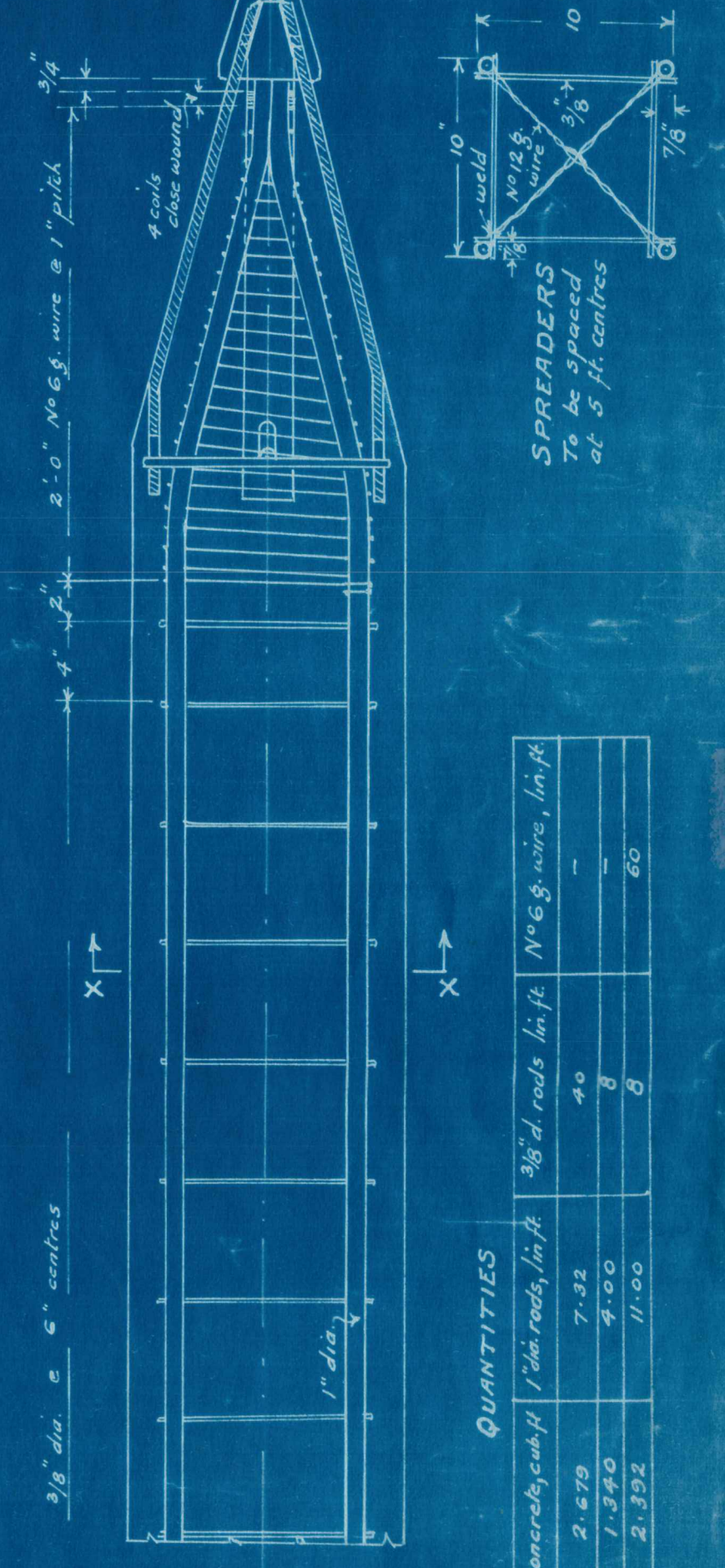
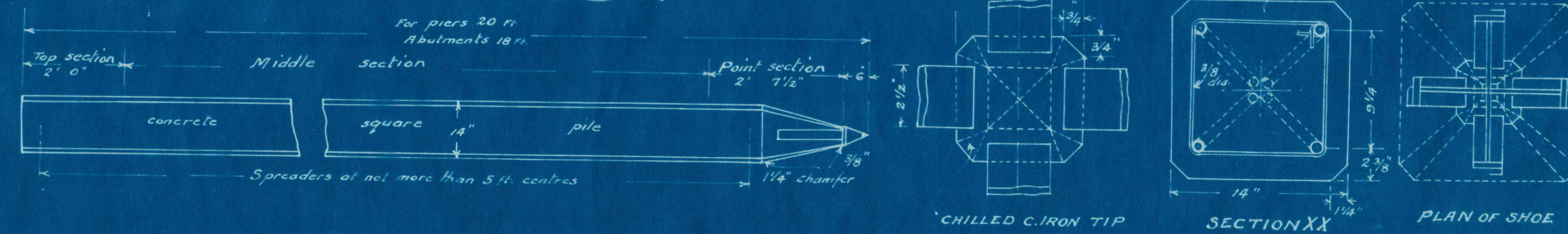
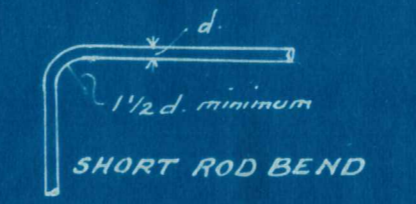
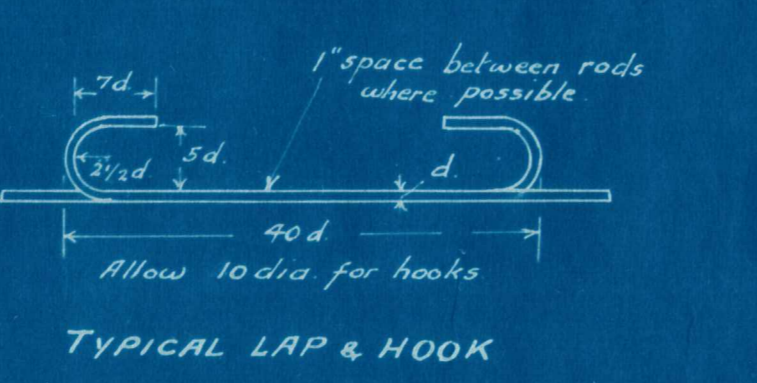

QUANTITIES

18" square pile (concrete cast 1/2 dia rods)	385	3/8" dia rods (in ft)	176
Top Section, 2 ft	2	7/16"	8
Mid. Sec. per ft from	1	3/8"	8
Paint, Sec. 2, 17/2"	2	11/16"	60

Minimum weight of Manroy - 8 Tons  
Piles to be picked up at three points.  
Spreads to be not more than 16 ft apart in storage.

1750  
M.C.C. 456

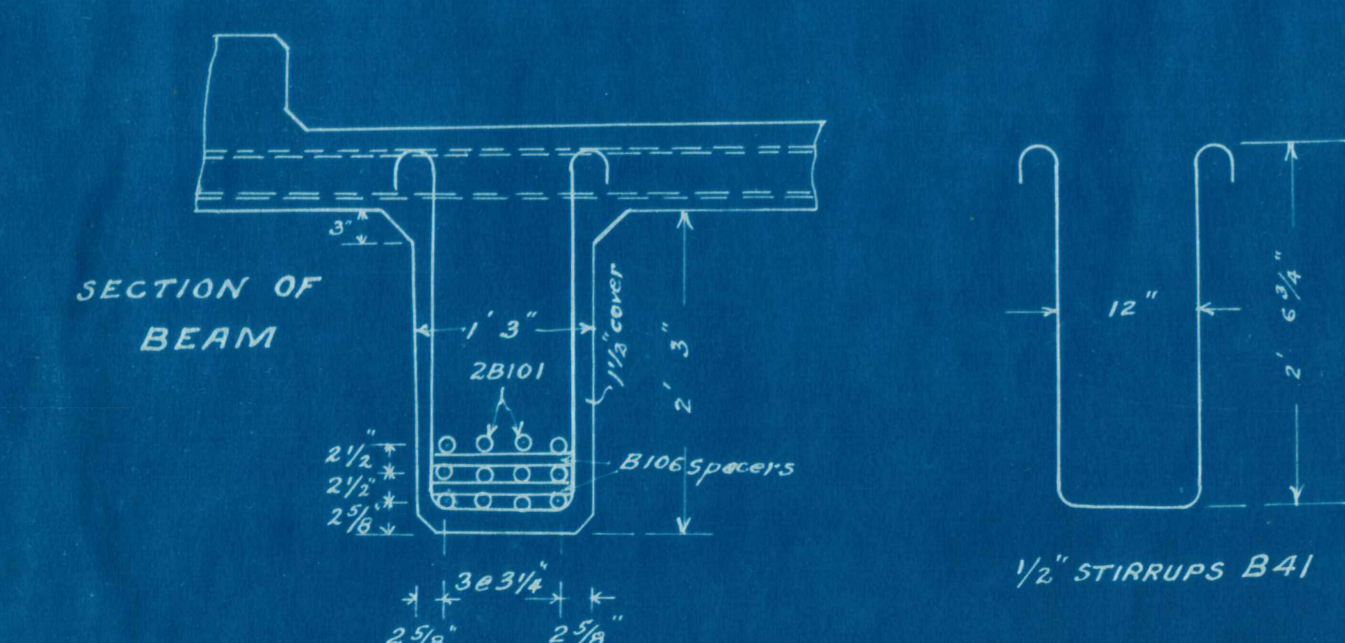
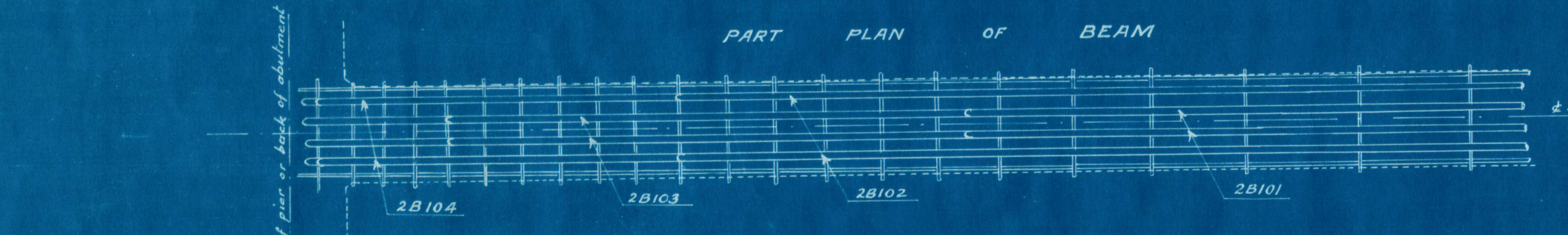
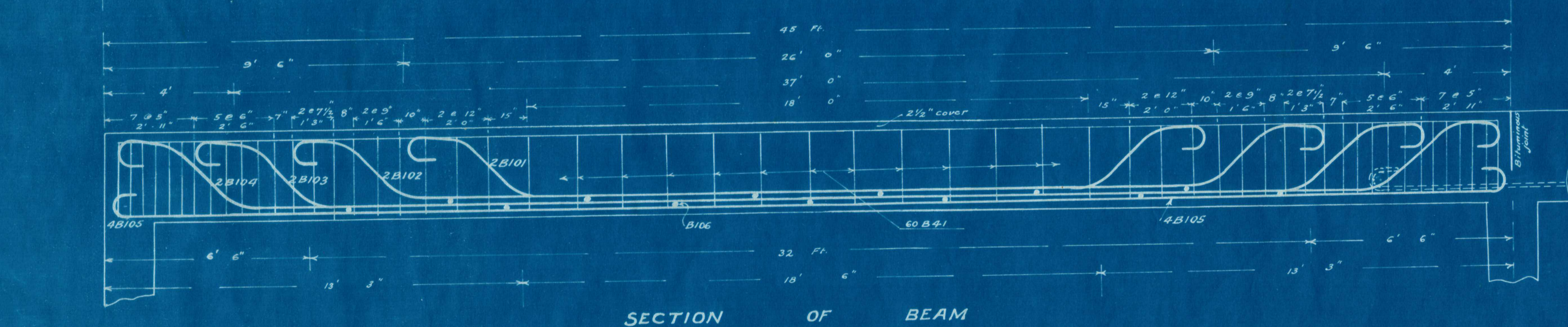
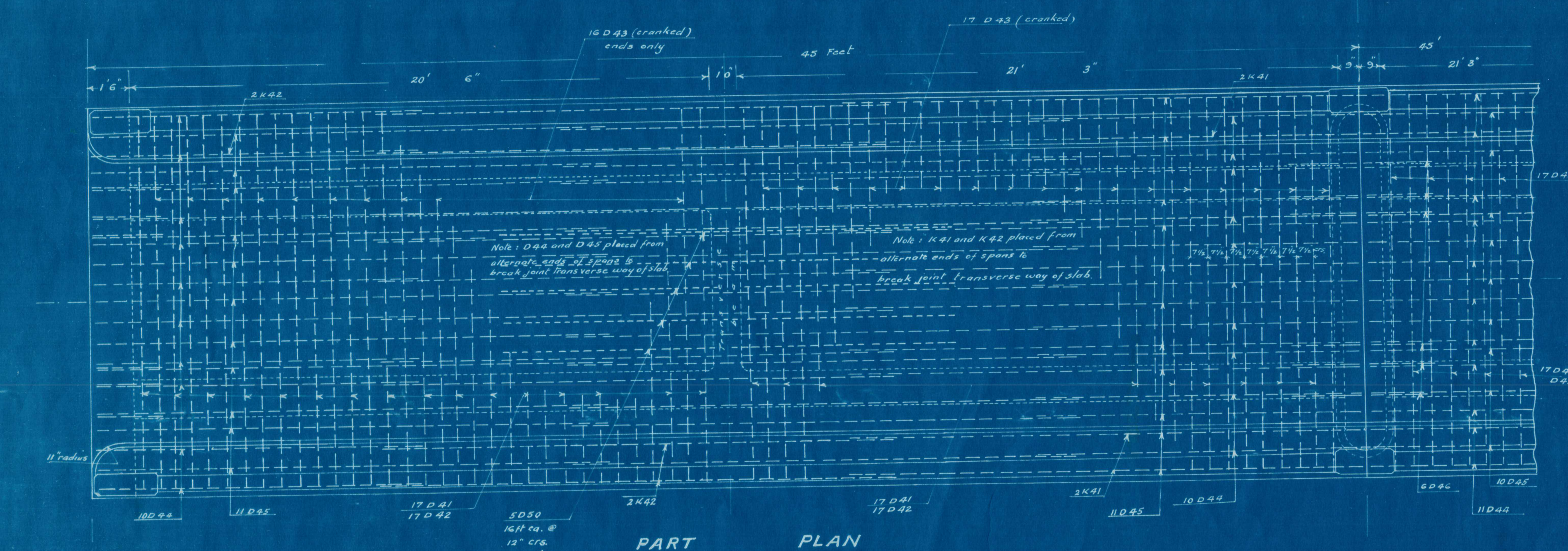
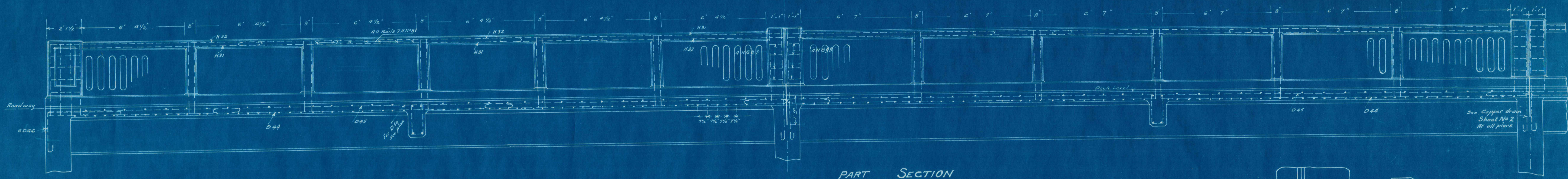

NOTATION OF RODS  
 A abutment  
 B beam  
 D deck  
 H handrails & posts  
 K kerb  
 P plate  
 T transverse beam  
 W wing-walls

10 definition 10 D44  
 10 No of rods in each  
 D location (deck)  
 4 diameter in eighths (1/2")  
 4 distinguishing No in shape from rods of equal dia

